

Adaptadores de cuerda para aplicaciones Ex d/e

APUS



Detalles Técnicos				
Material	Bronce, bronce latón niquelado, acero inoxidable 316L.			
O-Ring	CR (caucho de Cloropreno), Silicón			
Clasificación del Grado de Protección (IP)	IP 68 (5 bar, 30 min) IP 66			
Temperatura de Operación	Material de la glándula			
	<table border="1"> <tr> <th>CR (Cloropreno)</th> <th>Silicón</th> </tr> <tr> <td>-40°C a +100°C</td> <td>-60°C a +130°C</td> </tr> </table>	CR (Cloropreno)	Silicón	-40°C a +100°C
CR (Cloropreno)	Silicón			
-40°C a +100°C	-60°C a +130°C			
Ex d/e/tb				
Accesorio para	Atmósferas de gases y polvos potencialmente explosivas			
Adecuado para su uso en	Grupo II Gases Grupo IIC ZONA 1/ZONA 2 Grupo III Gases Grupo IIIC ZONA 21/ZONA 22			
Equipos marcados con	Ex II 2GD Ex db IIC Gb Ex eb IIC Gb Ex tb IIIC Db			
Ejemplo de marcaje	"BMD B-RB.. CE 0722 II 2GD Ex eb IIC Gb Ex tb IIIC Db Ta-40°C to +100°C IP66/68 CESI 13 ATEX 066X IECEx CES 13.0022X"			
Tipo de cuerda	<ul style="list-style-type: none"> Métrica (M) ISO Pitch 1.5 NPT (N) ANSI ASME B1.20.1 PG (P) DIN 40430 (G) GAS UNI ISO 228/1 			
Accesorios	<ul style="list-style-type: none"> Sellos (arandelas) 			
Comentarios	<ul style="list-style-type: none"> O-ring disponible en cuerdas métricas Todos los accesorios se venden por separado 			

Aprobaciones	Número de certificado	Estándares
	CESI 13 ATEX 066X	EN 60079-0:2012+A11:2013 EN 60079-1:2014 EN 60079-7:2015 EN 60079-31:2014
	IECEx CES 13.0022X	IEC 60079-0:2011 Edition:6 IEC 60079-1:2014 Edition:7 IEC 60079-31:2013 Edition:2 IEC 60079-7:2015 Edition:5
	Nº TC RU C-TR.AA87.B.00941	OCT 31610.0-2014 OCT IEC 60079-1:2013 OCT IEC 60079-31:2013
	DNV 12.0052 X	ABNT NBR IEC 60079-0:2008 ABNT NBR IEC 60079-1:2009 ABNT NBR IEC 60079-7:2008 ABNT NBR IEC 60079-31:2011
	E-14044	IEC/EN60079-0 IEC/EN60079-7 IEC/EN60079-31 IEC/EN60079-1 IEC/EN 62444

Para más información visita nuestra página web.

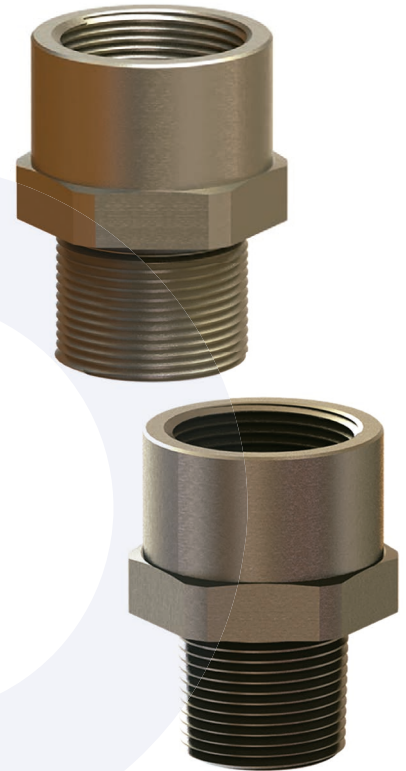

Adaptadores de cuerda para Aplicaciones Ex d/e

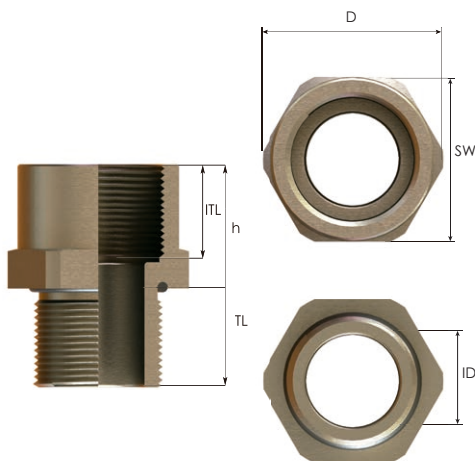

Tipo de cuerda METRICA acc. ISO 965 - 3

Tamaño de entrada de cuerda (macho)	Tamaño de salida de cuerda (hembra)	Longitud de cuerda		Ancho de llave SW mm	Diámetro exterior del capuchón del conector glándula D mm	Diámetro interior del capuchón del conector glándula ID mm	Altura máxima del conector h mm	Número de parte
		TL mm	ITL mm					
M16x1,5	M20x1,5	15,0	15,0	25	27,5	10,0	19,0	B-RB1M01M
	M25x1,5	15,0	15,0	30	33,0	10,0	19,0	B-RB2M01M
	M32x1,5	15,0	15,0	36	39,5	10,0	19,0	B-RB3M01M
M20x1,5	M25x1,5	15,0	15,0	30	33,0	14,0	19,0	B-RB2M1M
	M32x1,5	15,0	15,0	36	39,5	14,0	19,0	B-RB3M1M
	M40x1,5	15,0	18,0	45	50,0	14,0	22,0	B-RB4M1M
M25x1,5	M32x1,5	15,0	15,0	36	39,5	19,0	19,0	B-RB3M2M
	M40x1,5	15,0	18,0	45	50,0	19,0	22,0	B-RB4M2M
	M50x1,5	15,0	18,0	55	61,0	19,0	22,0	B-RB5M2M
M32x1,5	M40x1,5	15,0	18,0	45	50,0	26,0	22,0	B-RB4M3M
	M50x1,5	15,0	18,0	55	61,0	26,0	22,0	B-RB5M3M
	M60x1,5	18,0	18,0	68	75,0	26,0	22,5	B-RB6M3M
M40x1,5	M50x1,5	18,0	18,0	55	61,0	34,0	22,0	B-RB5M4M
	M60x1,5	18,0	18,0	68	75,0	34,0	22,5	B-RB6M4M
	M63x1,5	18,0	18,0	68	75,0	34,0	22,5	B-RB6M4M
	M70x1,5	18,0	18,0	80	88,5	34,0	22,5	B-RB7M4M
	M75x1,5	18,0	18,0	80	88,5	34,0	22,5	B-RB7M4M
M50x1,5	M60x1,5	18,0	18,0	68	75,0	44,0	22,5	B-RB6M5M
	M63x1,5	18,0	18,0	68	75,0	44,0	22,5	B-RB6M5M
	M70x1,5	18,0	18,0	80	88,5	44,0	22,5	B-RB7M5M
	M75x1,5	18,0	18,0	80	88,5	44,0	22,5	B-RB7M5M
	M80x1,5	18,0	18,0	90	100,0	44,0	22,5	B-RB8M5M
M60x1,5	M63x1,5	18,0	18,0	68	75,0	54,0	22,5	B-RB6M6M
	M70x1,5	18,0	18,0	80	88,5	54,0	22,5	B-RB7M6M
	M75x1,5	18,0	18,0	80	88,5	54,0	22,5	B-RB7M6M
	M80x1,5	18,0	18,0	90	100,0	54,0	22,5	B-RB8M6M
	M85x1,5	18,0	18,0	95	105,0	54,0	22,5	B-RB8M6M
	M90x1,5	18,0	21,0	95	105,0	54,0	25,5	B-RB8M6M
M63x1,5	M70x1,5	18,0	18,0	80	88,5	57,0	22,5	B-RB7M6M
	M75x1,5	18,0	18,0	80	88,5	57,0	22,5	B-RB7M6M
	M80x1,5	18,0	18,0	90	100,0	57,0	22,5	B-RB8M6M
	M85x1,5	18,0	18,0	95	105,0	57,0	22,5	B-RB8M6M
	M90x1,5	18,0	21,0	95	105,0	57,0	25,5	B-RB8M6M
M70x1,5	M75x1,5	18,0	18,0	80	88,5	64,0	22,5	B-RB7M7M
	M80x1,5	18,0	18,0	90	100,0	64,0	22,5	B-RB8M7M
	M85x1,5	18,0	18,0	95	105,0	64,0	22,5	B-RB8M7M
	M90x1,5	18,0	21,0	95	105,0	64,0	25,5	B-RB8M7M
M75x1,5	M80x1,5	18,0	18,0	90	100,0	69,0	22,5	B-RB8M7M
	M85x1,5	18,0	18,0	95	105,0	69,0	22,5	B-RB8M7M
	M90x1,5	18,0	21,0	95	105,0	69,0	25,5	B-RB8M7M
	M100x1,5	18,0	21,0	110	123,0	69,0	25,5	B-RB9M7M
	M85x1,5	18,0	21,0	95	105,0	72,0	22,5	B-RB8M8M
M80x1,5	M90x1,5	18,0	21,0	95	105,0	72,0	25,5	B-RB8M8M
	M100x1,5	18,0	21,0	110	123,0	72,0	25,5	B-RB9M8M
	M110x1,5	18,0	21,0	120	134,0	72,0	26,0	B-RB10M8M
	M90x1,5	18,0	21,0	95	105,0	77,0	25,5	B-RB8M8M
M85x1,5	M100x1,5	18,0	21,0	110	123,0	77,0	25,5	B-RB9M8M
	M110x1,5	18,0	21,0	120	134,0	77,0	26,0	B-RB10M8M
	M90x1,5	21,0	21,0	110	123,0	84,0	26,0	B-RB9M8M
M90x1,5	M110x1,5	21,0	21,0	120	134,0	84,0	26,0	B-RB10M8M
	M100x1,5	21,0	21,0	120	134,0	94,0	26,0	B-RB10M9M

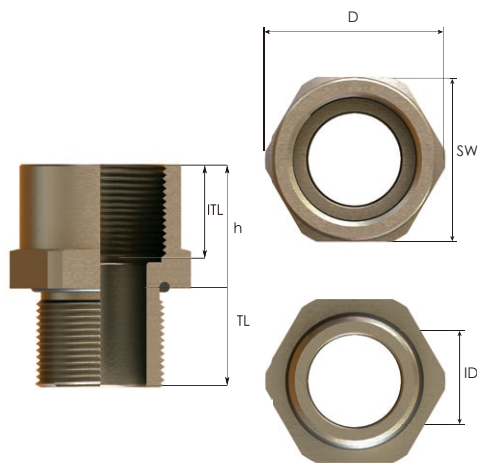

Tipo de cuerda **NPT** acc. ASME B1.20.1 > **METRIC** acc to. ISO 965 - 3

Tamaño de entrada de cuerda (macho)	Tamaño de salida de cuerda (hembra)	Longitud de cuerda		Ancho de llave SW mm	Diámetro exterior del capuchón del conector glándula D mm	Diámetro interior del capuchón del conector glándula ID mm	Altura máxima del conector h mm	Número de parte
		TL mm	ITL mm					
NPT 3/8"	M16x1,5	15,0	15,0	22	24,0	12,0	18,5	B-RB01M01N
	M20x1,5	15,0	15,0	25	27,5	12,0	19,0	B-RB1M01N
	M25x1,5	15,0	15,0	30	33,0	14,5	19,0	B-RB2M01N
	M32x1,5	15,0	15,0	36	39,5	12,0	19,0	B-RB3M01N
NPT 1/2"	M20x1,5	15,0	15,0	25	27,5	14,5	19,0	B-RB1M1N
	M25x1,5	15,0	15,0	30	33,0	14,5	19,0	B-RB2M1N
	M32x1,5	15,0	15,0	36	39,5	14,5	19,0	B-RB3M1N
	M40x1,5	15,0	18,0	45	50,0	14,5	22,0	B-RB4M1N
NPT 3/4"	M20x1,5	15,0	15,0	30	33,0	14,5	19,0	B-RB1M2N
	M32x1,5	15,0	15,0	36	39,5	19,0	19,0	B-RB3M2N
	M40x1,5	15,0	18,0	45	50,0	19,0	22,0	B-RB4M2N
	M50x1,5	18,0	18,0	55	61,0	19,0	22,0	B-RB5M2N
NPT 1"	M32x1,5	15,0	15,0	36,0	39,5	26,0	19,0	B-RB3M3N
	M40x1,5	15,0	18,0	45,0	50,0	26,0	22,0	B-RB4M3N
	M50x1,5	18,0	18,0	55,0	61,0	26,0	22,0	B-RB5M3N
	M60x1,5	18,0	18,0	68,0	75,0	26,0	22,5	B-RB6M3N
NPT 1 1/4"	M63x1,5	18,0	18,0	68,0	75,0	26,0	22,5	B-RB6M3N
	M40x1,5	18,0	18,0	45,0	50,0	35,0	22,0	B-RB4M4N
	M50x1,5	18,0	18,0	55,0	61,0	35,0	22,0	B-RB5M4N
	M60x1,5	18,0	18,0	68,0	75,0	35,0	22,5	B-RB6M4N
NPT 1 1/2"	M63x1,5	18,0	18,0	68,0	75,0	35,0	22,5	B-RB6M4N
	M70x1,5	18,0	18,0	80,0	88,5	35,0	22,5	B-RB7M4N
	M75x1,5	18,0	18,0	80,0	88,5	35,0	22,5	B-RB7M4N
	M50x1,5	18,0	18,0	55,0	61,0	40,0	22,0	B-RB5M5N
NPT 2"	M60x1,5	18,0	18,0	68,0	75,0	40,0	22,5	B-RB6M5N
	M63x1,5	18,0	18,0	68,0	75,0	40,0	22,5	B-RB6M5N
	M70x1,5	18,0	18,0	80,0	88,5	40,0	22,5	B-RB7M5N
	M75x1,5	18,0	18,0	80,0	88,5	40,0	22,5	B-RB7M5N
NPT 2 1/2"	M63x1,5	18,0	18,0	68,0	75,0	51,0	22,5	B-RB6M6N
	M70x1,5	18,0	18,0	80,0	88,5	51,0	22,5	B-RB7M6N
	M75x1,5	18,0	18,0	80,0	88,5	51,0	22,5	B-RB7M6N
	M80x1,5	18,0	18,0	90,0	100,0	51,0	23,0	B-RB8M6N
NPT 3"	M85x1,5	18,0	18,0	95,0	105,0	51,0	23,0	B-RB8M6N
	M90x1,5	28,0	21,0	95,0	105,0	51,0	26,0	B-RB8M6N
	M75x1,5	28,0	18,0	80,0	88,5	62,0	22,5	B-RB7M7N
	M80x1,5	28,0	18,0	90,0	100,0	62,0	23,0	B-RB8M7N
NPT 3 1/2"	M85x1,5	28,0	18,0	95,0	105,0	62,0	23,0	B-RB8M7N
	M85x1,5	28,0	18,0	95,0	105,0	62,0	23,0	B-RB8M7N
	M90x1,5	28,0	21,0	95,0	105,0	62,0	26,0	B-RB8M7N
	M85x1,5	28,0	18,0	95,0	105,0	75,0	23,0	B-RB8M8N
NPT 3"	M90x1,5	28,0	21,0	95,0	105,0	75,0	26,0	B-RB8M8N
	M100x1,5	28,0	21,0	110,0	123,0	75,0	26,0	B-RB9M8N
	M110x1,5	28,0	21,0	120,0	134,0	75,0	26,0	B-RB10M8N
	M100x1,5	28,0	21,0	110,0	123,0	87,0	26,0	B-RB9M9N
NPT 3 1/2"	M110x1,5	28,0	21,0	120,0	134,0	87,0	26,0	B-RB10M9N
	M110x1,5	28,0	21,0	120,0	134,0	100,0	26,0	B-RB10M10N

APUS Adaptadores de cuerda para aplicaciones Ex d/e

Adaptadores de cuerda
Áreas Clasificadas

Tipo de cuerda **NPT / NPT** acc.to ANSI ASME B1.20.1

Tamaño de entrada de cuerda (macho)	Tamaño de salida de cuerda (hembra)	Longitud de cuerda	Longitud de cuerda interior	Ancho de llave	Diámetro exterior del capuchón del conector glándula	Diámetro interior del capuchón del conector glándula	Altura máxima del conector	Número de parte
		TL mm	ITL mm	SW mm	D mm	ID mm	h mm	
NPT 3/8"	NPT 1/2"	15,0	15,0	25	27,5	13,0	19,0	B-RB1N01N
	NPT 3/4"	15,0	15,0	30	33,0	12,0	19,0	B-RB2N01N
	NPT 1"	15,0	15,0	30	39,5	12,0	19,0	B-RB3N01N
NPT 1/2"	NPT 3/4"	15,0	15,0	30	33,0	14,5	19,0	B-RB2N1N
	NPT 1"	15,0	15,0	36	39,5	14,5	19,0	B-RB3N1N
	NPT 1 1/4"	15,0	18,0	45	50,0	14,5	22,0	B-RB4N1N
NPT 3/4"	NPT 1"	15,0	15,0	36	39,5	20,0	19,0	B-RB3N2N
	NPT 1 1/4"	15,0	18,0	45	50,0	20,0	22,0	B-RB4N2N
	NPT 1 1/2"	15,0	18,0	55	61,0	20,0	22,5	B-RB5N2N
NPT 1"	NPT 1 1/4"	15,0	18,0	45	50,0	27,0	22,0	B-RB4N3N
	NPT 1 1/2"	15,0	18,0	55	61,0	25,0	22,5	B-RB5N3N
	NPT 2"	18,0	18,0	65	72,0	25,0	22,5	B-RB6N3N
NPT 1 1/4"	NPT 1 1/2"	18,0	18,0	55	61,0	40,5	22,5	B-RB5N4N
	NPT 2"	18,0	18,0	65	72,0	40,5	22,5	B-RB6N4N
	NPT 2 1/2"	18,0	28,0	80	88,5	35,0	32,5	B-RB7N4N
NPT 1 1/2"	NPT 2"	18,0	18,0	65	72,0	41,0	22,5	B-RB6N5N
	NPT 2 1/2"	18,0	28,0	80	88,5	41,0	32,5	B-RB7N5N
	NPT 3"	28,0	28,0	95	105,0	41,0	32,5	B-RB8N5N
NPT 2"	NPT 2 1/2"	18,0	28,0	80	88,5	53,0	32,5	B-RB7N6N
	NPT 3"	28,0	28,0	95	105,0	53,0	32,5	B-RB8N6N
	NPT 3 1/2"	28,0	28,0	110	123,0	53,0	33,0	B-RB9N6N
NPT 2 1/2"	NPT 3"	28,0	28,0	95	105,0	62,0	32,5	B-RB8N7N
	NPT 3 1/2"	28,0	28,0	110	123,0	62,0	33,0	B-RB9N7N
	NPT 4"	28,0	28,0	120	134,0	62,0	33,0	B-RB10N7N
NPT 3"	NPT 3 1/2"	28,0	28,0	110	123,0	75,0	33,0	B-RB9N8N
	NPT 4"	28,0	28,0	120	134,0	75,0	33,0	B-RB10N8N
NPT 3 1/2"	NPT 4"	28,0	28,0	120	134,0	87,5	33,0	B-RB10N9N

Tipo de cuerda **METRICA** acc. to ISO 965 - 3 > NPT acc to ANSI ASME B1.20.1

Tamaño de entrada de cuerda (macho)	Tamaño de salida de cuerda (hembra)	Longitud de cuerda	Longitud de cuerda interior	Ancho de llave	Diámetro exterior del capuchón del conector glándula	Diámetro interior del capuchón del conector glándula	Altura máxima del conector	Número de parte
		TL mm	ITL mm	SW mm	D mm	ID mm	h mm	
M16x1,5	NPT 3/8"	15,0	15,0	20	22,0	10,0	18,5	B-RB01N01M
	NPT 1/2"	15,0	15,0	25	27,5	10,0	19,0	B-RB1N01M
	NPT 3/4"	15,0	15,0	30	33,0	10,0	19,0	B-RB2N01M
M20x1,5	NPT 3/4"	15,0	15,0	30	33,0	14,0	19,0	B-RB2N1M
	NPT 1"	15,0	15,0	36	39,5	14,0	19,0	B-RB3N1M
	NPT 1 1/4"	15,0	18,0	45	50,0	14,0	22,0	B-RB4N1M
M25x1,5	NPT 3/4"	15,0	15,0	30	33,0	19,0	19,0	B-RB2N2M
	NPT 1"	15,0	15,0	36	39,5	19,0	19,0	B-RB3N2M
	NPT 1 1/4"	15,0	18,0	45	50,0	19,0	22,0	B-RB4N2M
M32x1,5	NPT 1"	15,0	15,0	36	39,5	26,0	19,0	B-RB3N3M
	NPT 1 1/4"	15,0	18,0	45	50,0	26,0	22,0	B-RB4N3M
	NPT 1 1/2"	18,0	18,0	55	61,0	26,0	22,0	B-RB5N3M
M40x1,5	NPT 1 1/4"	18,0	18,0	45	50,0	34,0	22,0	B-RB4N4M
	NPT 1 1/2"	18,0	18,0	55	61,0	34,0	22,5	B-RB5N4M
	NPT 2"	18,0	18,0	65	72,0	34,0	22,5	B-RB6N4M
M50x1,5	NPT 1 1/2"	18,0	18,0	55	61,0	40,0	22,0	B-RB5N5M
	NPT 2"	18,0	18,0	65	72,0	44,0	22,5	B-RB6N5M
	NPT 2 1/2"	18,0	28,0	80	88,5	44,0	32,5	B-RB7N5M
M60x1,5	NPT 2"	18,0	18,0	68	75,0	48,0	22,5	B-RB6N6M
	NPT 2 1/2"	18,0	28,0	80	88,5	54,0	32,5	B-RB7N6M
	NPT 3"	18,0	28,0	95	105,0	54,0	32,5	B-RB8N6M
M63x1,5	NPT 2"	18,0	18,0	68	75,0	51,0	22,5	B-RB6N6M
	NPT 2 1/2"	18,0	28,0	80	88,5	57,0	32,5	B-RB7N6M
	NPT 3"	18,0	28,0	95	105,0	51,0	32,5	B-RB8N6M
M70x1,5	NPT 2 1/2"	18,0	28,0	80	88,5	64,0	32,5	B-RB7N7M
	NPT 3"	18,0	28,0	95	105,0	64,0	32,5	B-RB8N7M
	NPT 3 1/2"	18,0	28,0	110	123,0	64,0	33,0	B-RB9N7M
M75x1,5	NPT 2 1/2"	18,0	28,0	80	88,5	69,0	32,5	B-RB7N7M
	NPT 3"	18,0	28,0	95	105,0	69,0	32,5	B-RB8N7M
	NPT 3 1/2"	18,0	28,0	110	123,0	69,0	33,0	B-RB9N7M
M80x1,5	NPT 3"	18,0	28,0	95	105,0	72,0	32,5	B-RB8N8M
	NPT 3 1/2"	18,0	28,0	110	123,0	72,0	33,0	B-RB9N8M
	NPT 4"	18,0	28,0	120	134,0	72,0	33,0	B-RB10N8M
M85x1,5	NPT 3"	18,0	28,0	95	105,0	77,0	32,5	B-RB8N8M
	NPT 3 1/2"	18,0	28,0	110	123,0	77,0	33,0	B-RB9N8M
	NPT 4"	18,0	28,0	120	134,0	77,0	33,0	B-RB10N8M
M90x1,5	NPT 3"	21,0	28,0	95	105,0	78,0	33,0	B-RB8N8M
	NPT 3 1/2"	21,0	28,0	110	123,0	78,0	33,0	B-RB9N8M
	NPT 4"	21,0	28,0	120	134,0	78,0	33,0	B-RB10N8M
M100x1,5	NPT 3 1/2"	21,0	28,0	110	123,0	94,0	33,0	B-RB9N9M
	NPT 4"	21,0	28,0	120	134,0	94,0	33,0	B-RB10N9M
M110x1,5	NPT 4"	21,0	28,0	120	134,0	103,0	33,0	B-RB10N10M